

## KLT-IRSW-OS05A20 V3.0

### 5MP OmniVision OS05A20 IR Switch MIPI Interface Fixed Focus Camera Module

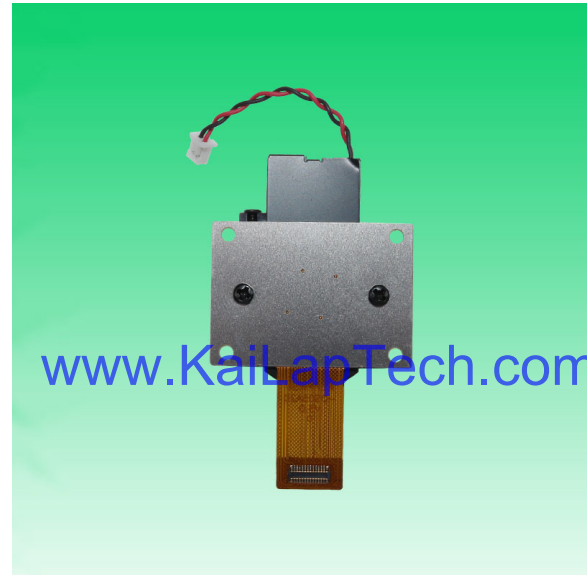

|                           |   |
|---------------------------|---|
| Camera Module No.         | <b>KLT-IRSW-OS05A20 V3.0</b>            |
| Resolution                | 5MP                                     |
| Image Sensor              | OS05A20                                 |
| Sensor Type               | 1/2.7"                                  |
| Pixel Size                | 2.0 um x 2.0 um                         |
| EFL                       | 1.95 mm                                 |
| F.NO                      | 2.20                                    |
| Pixel                     | 2688 x 1944                             |
| View Angle                | 180.0°(DFOV) 171.5°(HFOV) 118.0°(VFOV)  |
| Lens Dimensions           | 22.20 x 21.50 x 12.96 mm                |
| Module Size               | 50.00 x 30.00 mm                        |
| Module Type               | Fixed Focus                             |
| Lens Model                | KLT-LENS-E3335C                         |
| IR Switch Input Voltage   | 3.3V - 5.5V                             |
| Lens Filter IR Frequency  | 645nm +/- 15nm                          |
| Lens Filter AR Frequency  | 700nm - 1,000nm                         |
| Operation (IR Day Time)   | Red Line: Negative Black Line: Positive |
| Operation (AR Night Time) | Red Line: Positive Black Line: Negative |
| IR Switch Connector       | 962-10231-030005 (2 Pin)                |
| Interface                 | MIPI                                    |
| Operating Temperature     | -30°C to +85°C                          |
| Mating Connector          | WP7A-S024VA1                            |



## KLT-IRSW-OS05A20 V3.0

5MP OmniVision OS05A20 IR Switch MIPI Interface Fixed Focus Camera Module

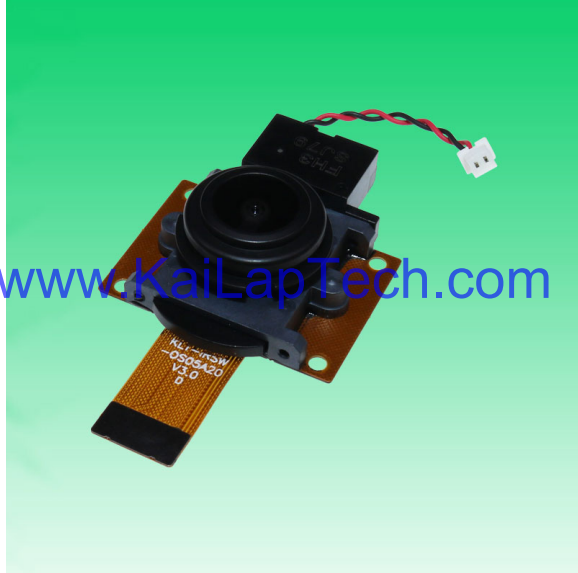

Top View



Side View

www.KaiLapTech.com

www.KaiLapTech.com



Bottom View



Mating Connector

# ROHS

PIN SIGNAL

|    |             |
|----|-------------|
| 1  | AGND        |
| 2  | AVDD2.8V    |
| 3  | SDA         |
| 4  | SCL         |
| 5  | PWDN        |
| 6  | RST/XSHUNDN |
| 7  | MCP         |
| 8  | MCN         |
| 9  | DGND        |
| 10 | MDP0        |
| 11 | MDN0        |
| 12 | DGND        |
| 13 | MDP1        |
| 14 | MDN1        |
| 15 | DGND        |
| 16 | MDP2        |
| 17 | MDN2        |
| 18 | DGND        |
| 19 | MDP3        |
| 20 | MDN3        |
| 21 | DGND        |
| 22 | DVDD1.2V    |
| 23 | DVDD1.8V    |
| 24 | MCLK        |

Parameter:

1. Sensor specification:

Image Sensor: OS05A20

Pixel: 2umx2um

Lens Type: 1/2.7

Important Voltage Description: DVDD1.2V (external power supply);

2. Lens specification:

FOV: 180°(D),171.5°(H),118°(V)

F/No: 2.2

OP Distortion: <-9%

Focal length: 1.95mm

Composition: 6G+IR Switch

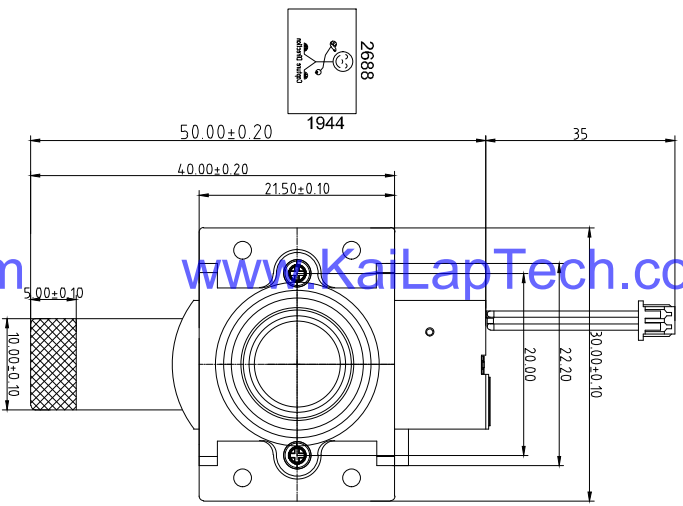

TOP VIEW

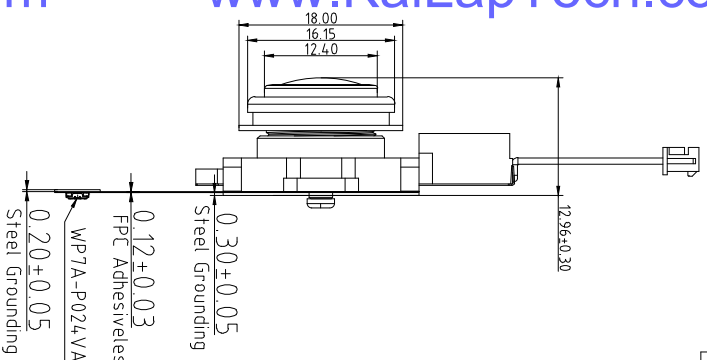

SIDE VIEW

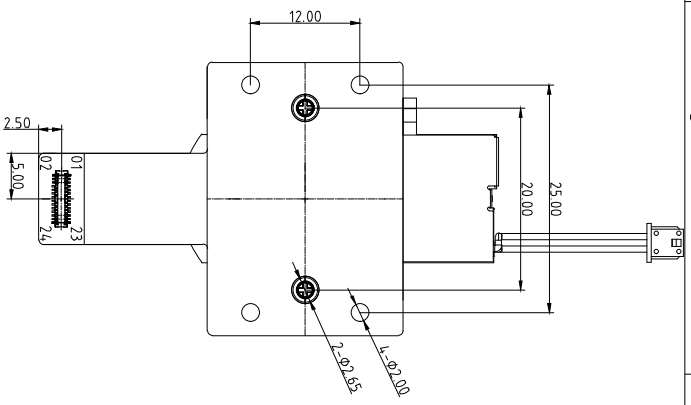

BOTTOM VIEW

NOTE:  
1.The device slave  
address:0x6C(w),0x6D(r)

| Version Mark | Information            | Date       |
|--------------|------------------------|------------|
| V1.0         | PD First Version       | 2019-03-23 |
| V2.0         | Connector changed      | 2019-03-23 |
| V3.0         | Change lens and IR CUT | 2019-10-29 |

Kai Lap Technologies Group Ltd

Designed By

Kevin

Model Name:

KLT-IRSW-OS05A20 V3.0

Checked By

Aouly

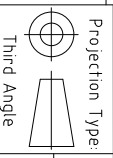

Unit: mm

Scale: 1:1

Sheet: 1 of 1

Version: 1/0

A

B

C

D

E

3

3

2

2

1

1



Lens Model: KLT-LENS-E3335C

| SPECIFICATION SHEET          |   |
|------------------------------|---|
| Material No. 物料号             | /   |
| 传感器规格 Sensor Spec            | CCD/CMOS  |
| 最大像面 Max Image Circle        | Ø5.6mm  |
| EFL 有效焦距                     | 1.95mm  |
| FNo. F值                      | F2.2  |
|                              | OS05A20   |
| F.O.V. 视场角                   | D 对角 180°(5.57mm)<br>H 水平 171.5°(5.376mm)<br>V 垂直 118°(3.888mm) |
| Back Focal Length 后焦距        | 3.07mm (0.3mm filter +0.4 cover glass)                          |
| Lens Effective Diameter 有效口径 | Front Ø9.4mm<br>Back Ø6mm                                       |
| Lens construction 镜头组成       | 6-5(SAG)  |
| OP Distortion 光学畸变           | -9%   |
| Resolution 分辨率               | Mega pixel  |
| Relative Illumination 相对照度   | >40%  |
| Iris 光圈                      | Fixed   |
| Max Chief Ray Angle 最大主光线入射角 | 15.6±3°   |
| Mount 接口                     | M12X0.5   |
| TTL 光学总长                     | 12.2mm (0.3mm filter +0.4 cover glass)                          |
| Dimension (ØxL) 外形尺寸         | Ø18x12.5  |
| Filter Spec 滤光片规格            | /   |

| REV. NO. | DATE      | DESCRIPTION | DESIGNED | CHECKED | NAME  | DATE |
|----------|-----------|-------------|----------|---------|-------|------|
| 00       | 2019.6.30 | 新模作成        | JLQ      | XJL     | AUDI. |      |

**Image Circle vs. Sensor Format**

**UNLESS TOLERANCE**

Ø: JIS B 1301 | P: JIS B 1302 | 350 Angle Projection

客户确认  
签章处

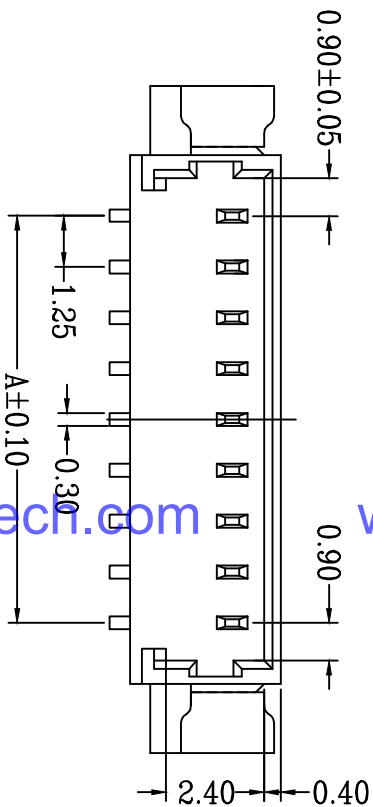
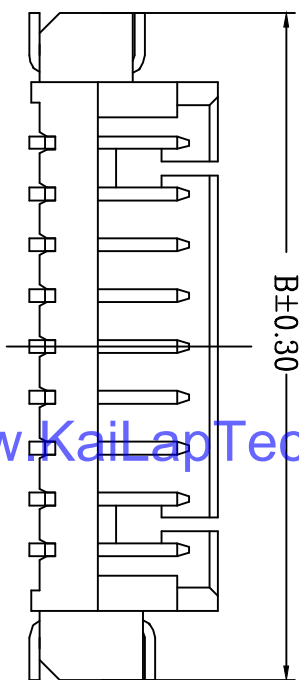

NOTES:

Current Rating: 0.3A AC,DC  
Voltage Rating: 100V AC,DC  
Temperature Range: -25°C to +85°C  
Contact Resistance: 20mΩ Max  
Insulation Resistance: 100MΩ min  
Withstanding Voltage: 300V AC/minute  
PIN Material: phosphor bronze Tin plated  
Material: LCP UL94V-0 ROHS

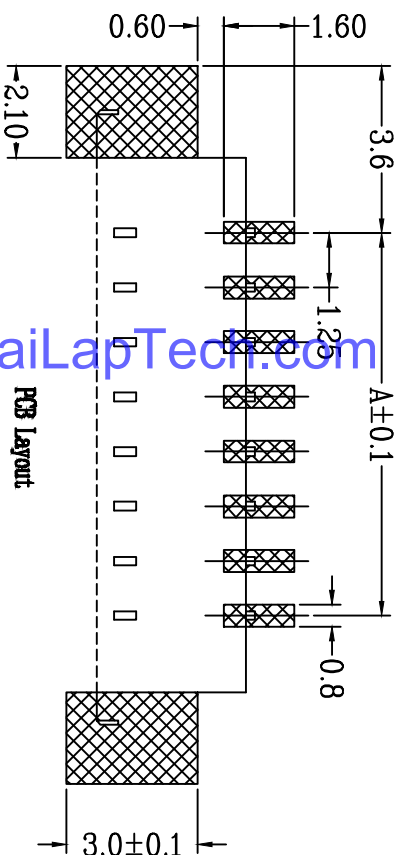
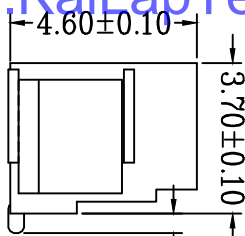

| PIN | A     | B     |
|-----|-------|-------|
| 2   | 1.25  | 7.70  |
| 3   | 2.50  | 8.95  |
| 4   | 3.75  | 10.20 |
| 5   | 5.00  | 11.45 |
| 6   | 6.25  | 12.70 |
| 7   | 7.50  | 13.95 |
| 8   | 8.75  | 15.20 |
| 9   | 9.00  | 16.45 |
| 10  | 10.25 | 17.70 |
| 11  | 11.50 | 18.95 |
| 12  | 12.75 | 20.20 |
| 13  | 13.00 | 21.45 |
| 14  | 14.25 | 22.70 |
| 15  | 15.50 | 23.95 |
| 16  | 16.25 | 25.20 |



深圳市福金鹰电子有限公司  
SHENZHEN FJY ELECTRONICS CO., LTD.

DATE: 16/08/16

GENERAL TOLERANCE UNLESS OTHERWISE NOTED

TITLE: PH1.25mm Water 米色 环保料

DRAW: CKX Date: 16/08/16

PART No: 962-10231-030005

CHECK: Date: 16/08/16

SCALE: 1:1

APPNO: Date: 16/08/16

TM/00765-2788310/1/12 P&C/00765-2788300/1/13 E-MARKETING/0765.com Http://www.fjytc.com

**NEW**



0.4mm Pitch, Stacking Type  
Board-to-Board (FPC) Connector

CONNECTOR

MB-0228-3

September 2017

# WP7 Series

**RoHS Compliant**

Plug

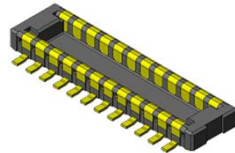

Plug

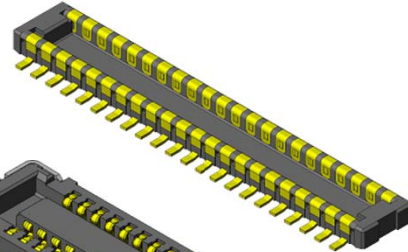

[www.KaiLapTech.com](http://www.KaiLapTech.com)

[www.KaiLapTech.com](http://www.KaiLapTech.com)

Receptacle

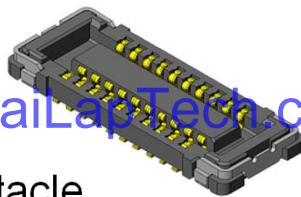

Receptacle

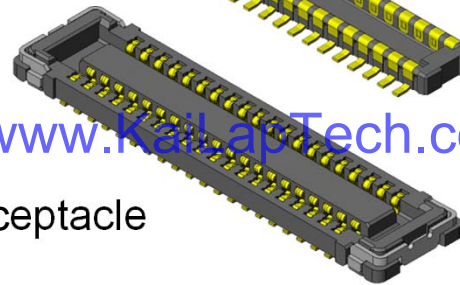

The WP7 Series is a low-profile board-to-board (FPC) connector with 0.4mm pitch spacing that is ideal for high-density mounting in slim information communication devices like mobile phones, smartphones, LCD, and notebook PC.

To satisfy different product function requirements, a low pin count type and a high pin count type (WP7A / WP7B) are available with the same mounting pattern.

## Features

- 0.4mm pitch, 2 rows, 0.7mm stacking height.
- Contact structure ensures high wear-resistance and high contact reliability.
- Secure hold-downs prevent insulator breakage and peeling from FPC.
- 2-point contact design to resist twisting stress.
- Pb-free (Ni barrier on contact prevents solder wicking.)
- Receptacle contacts adopt an optimal configuration according to the pin counts.

High removal force WP7A (low pin count: 10-32 pos.)

Low insertion force WP7B (high pin count 34-70 pos.)

- Signal contact supports 10 Gbps transmission rate.
- Supports MIPI, USB3.1 Gen2, and PCIe Gen3 transmission.

## General Specifications

- |   |   |
|---|---|
| <ul style="list-style-type: none"> <li>■(WP7A) No. of Contacts:<br/>10, 16, 20, 22, 24, 26,<br/>28, 30, 32 pos.</li> <li>■(WP7B) No. of Contacts:<br/>34, 40, 50, 60, 70 pos.</li> <li>■Pitch: 0.4mm, 2 rows</li> <li>■Operating Temperature:<br/>-40 Deg. C to +85 Deg. C</li> <li>■Contact Resistance:<br/>70mΩ max. (initial)</li> <li>■Life Time: 30 mating cycles</li> </ul> | <ul style="list-style-type: none"> <li>■Rated Current: AC, DC 0.3A each per terminal</li> <li>■Rated Voltage: AC, DC 50V</li> <li>■Insulation Resistance: 100MΩ min. (initial)</li> <li>■Dielectric Withstanding Voltage:<br/>AC250Vr.m.s for 1 minute</li> <li>■(WP7A) total insertion force:<br/>1.50N x n max. (n: No. of pos.)</li> <li>■(WP7A) total removal force:<br/>0.15N x n min. (n: No. of pos.)</li> <li>■(WP7B) total insertion force:<br/>1.00N x n max. (n: No. of pos.)</li> <li>■(WP7B) total removal force:<br/>0.10N x n min. (n: No. of pos.)</li> </ul> |
|---|---|

Materials and Finishes

|           |  |
|-----------|--|
| Component | Material / Finish  |
| Contact   | Cu alloy / Au plating  |
| Insulator | Heat-resistant plastic   |
| Hold-Down | Plug: Cu alloy / Au plating<br>Receptacle: Cu alloy / Sn plating |

Ordering Information (Plug)

[www.KaiLapTech.com](http://www.KaiLapTech.com)

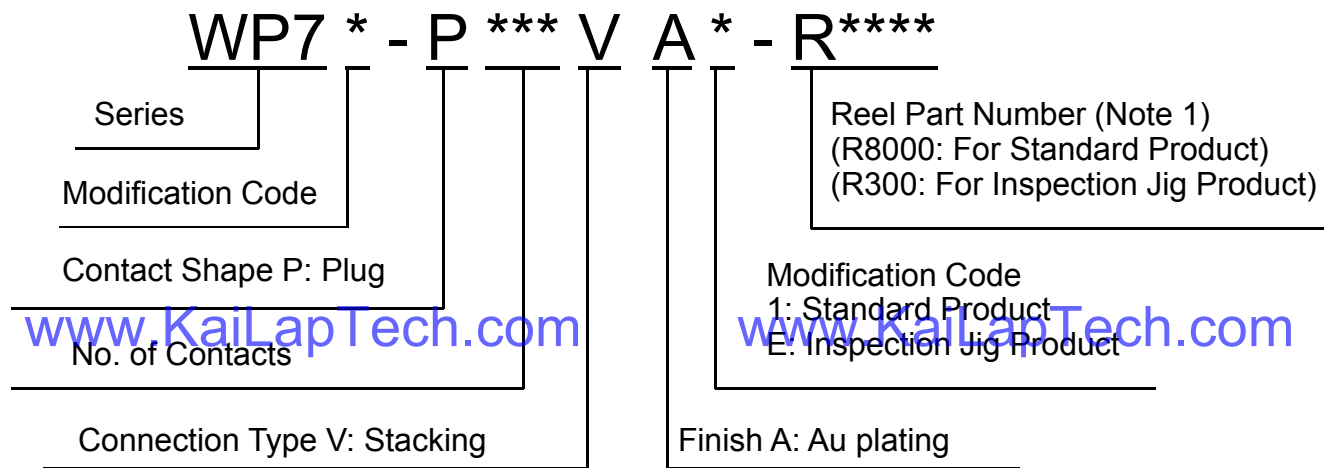

Ordering Information (Receptacle)

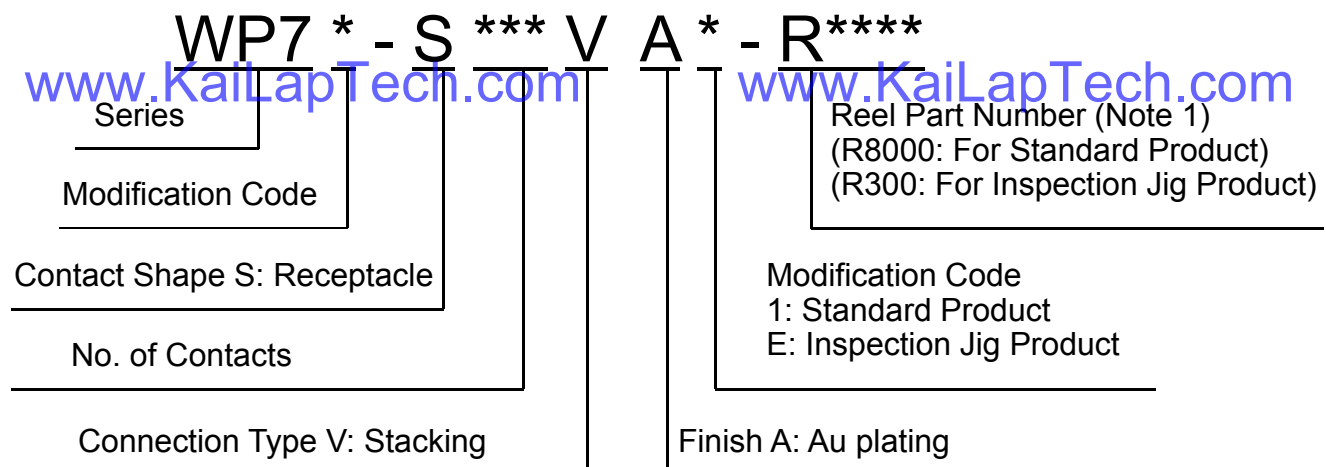

Note 1) An embossed tape reel contains 8,000 pieces of standard product, or 300 pieces of inspection jig product. Please contact us for details on embossed tape specifications.

|             |              |
|-------------|--------------|
| Part Number | WP7A-S***VA1 |
| SJ Drawing  | SJ111877     |

# WP7A Receptacle

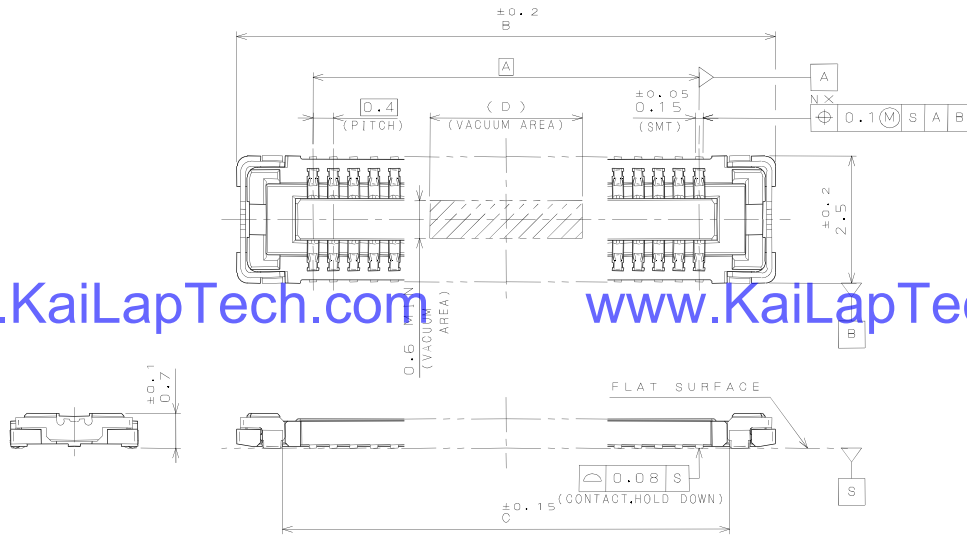

www.KaiLapTech.com

www.KaiLapTech.com

www.KaiLapTech.com

www.KaiLapTech.com

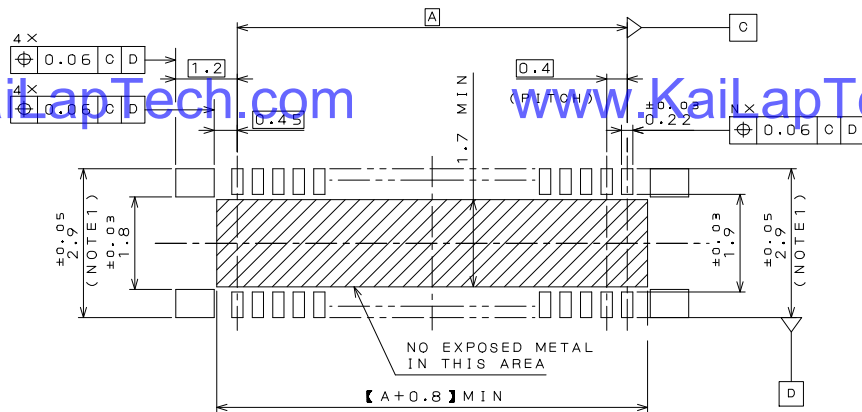

APPLICABLE P.C.B. DIMENSION (REF.)  
適合基板寸法 (参考)

www.KaiLapTech.com

www.KaiLapTech.com

| NUMBER OF CONTACT<br>芯数 | DIMENSIONS<br>寸法 |     |     |     |
|-------------------------|------------------|-----|-----|-----|
|                         | A                | B   | C   | D   |
| 10                      | 1.6              | 4.6 | 2.8 | 2.0 |
| 16                      | 2.8              | 5.8 | 4.0 | 2.0 |
| 20                      | 3.6              | 6.6 | 4.8 | 2.0 |
| 22                      | 4.0              | 7.0 | 5.2 | 2.0 |
| 24                      | 4.4              | 7.4 | 5.6 | 2.0 |
| 26                      | 4.8              | 7.8 | 6.0 | 5.0 |
| 28                      | 5.2              | 8.2 | 6.4 | 5.0 |
| 30                      | 5.6              | 8.6 | 6.8 | 5.0 |
| 32                      | 6.0              | 9.0 | 7.2 | 5.0 |

Note 1) Dimension 3.5±0.05 is recommended in case repair is needed.



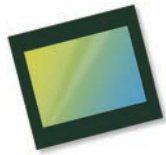

# OS05A20 5-megapixel product brief



## New OS05A20 Uses Nyxel® Technology to Bring Superior Image Quality to Video Surveillance Cameras

### Day or Night



available in a lead free package

The 5-megapixel OS05A20 is the world's first image sensor to implement Nyxel® technology, OmniVision's breakthrough near-infrared (NIR) technology that allows image sensors to see better and farther under low- and no-light conditions. By using Nyxel® technology and a 2 x 2 micron pixel, the OS05A20 PureCel® image sensor has the unique ability to capture high-quality, high-resolution day or night, making it ideally suited for professional surveillance systems.

Nyxel® technology combines thick-silicon pixel architectures with extended deep trench isolation (DTI) to improve quantum efficiency (QE) up to 3x for 850 nm sensitivity and up to 5x for 940 nm sensitivity, while

maintaining all other image-quality metrics. These improvements deliver unrivaled image quality, extended image-detection range and a reduced light-source requirement, leading to lower power consumption.

Available in a 1/2.7-inch optical format, the OS05A20 is capable of capturing full-resolution 2688 x 1944 video at 60 frames per second (fps), 1080p full high definition (HD) video at 120 fps, and 720p HD video at 180 fps. The sensor comes in a chip scale package (CSP).

Find out more at [www.ovt.com](http://www.ovt.com).



## Applications

- Security Cameras
- High Resolution Consumer Cameras
- Action Cameras

## Product Features

- 2  $\mu\text{m}$  x 2  $\mu\text{m}$  pixel
- optical size of 1/2.7"
- QE enhancement in 850 nm and 940 nm
- programmable controls for:
  - frame rate
  - mirror and flip
  - cropping
  - windowing
- supports output formats:
  - 12/10-bit RAW/RGB
- supports images sizes:
  - 2688 x 1944
  - 1080p (1920x1080)
  - 720p (1280x720)
- supports 2x2 binning
- standard serial SCCB interface
- 12/10-bit ADC
- up to 4-lane MIPI/LVDS serial output interface (supports maximum speed up to 1500 Mbps/lane)
- 2-exposure staggered HDR support
- programmable I/O drive capability
- light sensing mode (LSM)
- PLL with SCC support
- support for frame sync

# OS05A20



## Ordering Information

- OS05A20-H73A-1B (color, lead-free) 73-pin CSP
- OS05A20-H73A-1C (color, lead-free) 73-pin CSP

## Technical Specifications

- active array size: 2688 x 1944
- maximum image transfer rate:
  - 2688 x 1944: 60 fps
  - 2688 x 1520: 60 fps
- power supply:
  - core: 1.2V
  - analog: 2.8V
  - I/O: 1.8V
- power requirements:
  - active: 210 mW
  - standby: 2 mA
  - XSHUTDOWN: 2  $\mu\text{A}$
- temperature range:
  - operating: -30°C to +85°C junction temperature
  - stable image: 0°C to +60°C junction temperature
- output formats: 10/12-bit RGB RAW
- lens size: 1/2.7"
- lens chief ray angle: 11° linear
- scan mode: progressive
- pixel size: 2.0  $\mu\text{m}$  x 2.0  $\mu\text{m}$
- image area: 5434.56  $\mu\text{m}$  x 3948.05  $\mu\text{m}$

## Functional Block Diagram

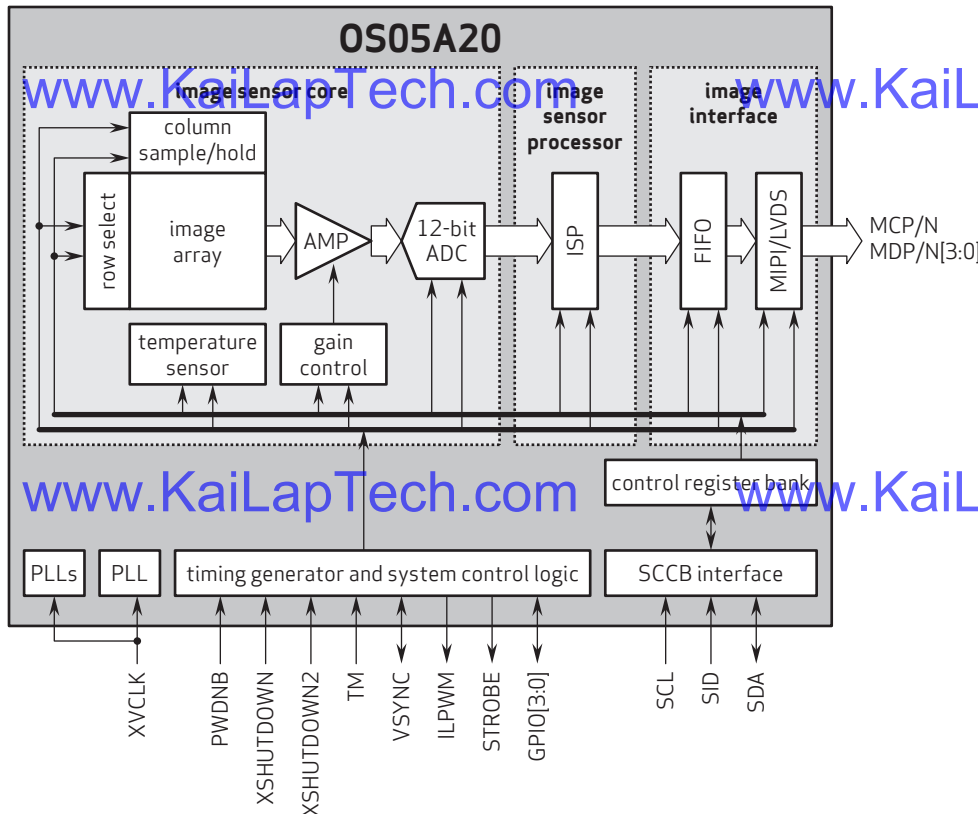

4275 Burton Drive  
Santa Clara, CA 95054  
USA

Tel: + 1 408 567 3000  
Fax: + 1 408 567 3001  
www.ovt.com

OmniVision reserves the right to make changes to their products or to discontinue any product or service without further notice. OmniVision, the OmniVision logo, PureCel, and Nyxel are registered trademarks of OmniVision Technologies, Inc. All other trademarks are the property of their respective owners.



OmniVision

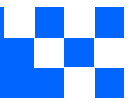

## Camera Module Pinout Definition Reference Chart

| OmniVision                    | Sony | Samsung   | On-Semi | Aptina | Himax | GalaxyCore | PixArt | SmartSens | Sensors |
|-------------------------------|------|---|---------|--------|-------|------------|--------|-----------|---------|
| Pin Signal                    |      | Description   |         |        |       |            |        |           |         |
| DGND GND                      |      | ground for digital circuit                              |         |        |       |            |        |           |         |
| AGND                          |      | ground for analog circuit                               |         |        |       |            |        |           |         |
| PCLK DCK                      |      | DVP PCLK output   |         |        |       |            |        |           |         |
| XCLR PWDN XSHUTDOWN STANDBY   |      | power down active high with internal pull-down resistor |         |        |       |            |        |           |         |
| MCLK XVCLK XCLK INCK          |      | system input clock                                      |         |        |       |            |        |           |         |
| RESET RST                     |      | reset active low with internal pull-up resistor         |         |        |       |            |        |           |         |
| NC NULL                       |      | no connect  |         |        |       |            |        |           |         |
| SDA SIO_D SIOD                |      | SCCB data   |         |        |       |            |        |           |         |
| SCL SIO_C SIOC                |      | SCCB input clock  |         |        |       |            |        |           |         |
| VSYNC XVS FSYNC               |      | DVP VSYNC output  |         |        |       |            |        |           |         |
| HREF XHS                      |      | DVP HREF output   |         |        |       |            |        |           |         |
| DOVDD                         |      | power for I/O circuit                                   |         |        |       |            |        |           |         |
| AFVDD                         |      | power for VCM circuit                                   |         |        |       |            |        |           |         |
| AVDD                          |      | power for analog circuit                                |         |        |       |            |        |           |         |
| DVDD                          |      | power for digital circuit                               |         |        |       |            |        |           |         |
| STROBE FSTROBE                |      | strobe output   |         |        |       |            |        |           |         |
| FSIN                          |      | synchronize the VSYNC signal from the other sensor      |         |        |       |            |        |           |         |
| SID                           |      | SCCB last bit ID input                                  |         |        |       |            |        |           |         |
| ILPWM                         |      | mechanical shutter output indicator                     |         |        |       |            |        |           |         |
| FREQ                          |      | frame exposure / mechanical shutter                     |         |        |       |            |        |           |         |
| GPIO                          |      | general purpose inputs                                  |         |        |       |            |        |           |         |
| SLASEL                        |      | I2C slave address select                                |         |        |       |            |        |           |         |
| AFEN                          |      | CEN chip enable active high on VCM driver IC            |         |        |       |            |        |           |         |
| <b>MIPI Interface</b>         |      |   |         |        |       |            |        |           |         |
| MDN0 DN0 MD0N DATA_N DMO1N    |      | MIPI 1st data lane negative output                      |         |        |       |            |        |           |         |
| MDP0 DP0 MD0P DATA_P DMO1P    |      | MIPI 1st data lane positive output                      |         |        |       |            |        |           |         |
| MDN1 DN1 MD1N DATA2_N DMO2N   |      | MIPI 2nd data lane negative output                      |         |        |       |            |        |           |         |
| MDP1 DP1 MD1P DATA2_P DMO2P   |      | MIPI 2nd data lane positive output                      |         |        |       |            |        |           |         |
| MDN2 DN2 MD2N DATA3_N DMO3N   |      | MIPI 3rd data lane negative output                      |         |        |       |            |        |           |         |
| MDP2 DP2 MD2P DATA3_P DMO3P   |      | MIPI 3rd data lane positive output                      |         |        |       |            |        |           |         |
| MDN3 DN3 MD3N DATA4_N DMO4N   |      | MIPI 4th data lane negative output                      |         |        |       |            |        |           |         |
| MDP3 DP3 MD3P DATA4_P DMO4P   |      | MIPI 4th data lane positive output                      |         |        |       |            |        |           |         |
| MCN CLKN CLK_N DCKN           |      | MIPI clock negative output                              |         |        |       |            |        |           |         |
| MCP CLKP MCP CLK_P DCKN       |      | MIPI clock positive output                              |         |        |       |            |        |           |         |
| <b>DVP Parallel Interface</b> |      |   |         |        |       |            |        |           |         |
| D0 DO0 Y0                     |      | DVP data output port 0                                  |         |        |       |            |        |           |         |
| D1 DO1 Y1                     |      | DVP data output port 1                                  |         |        |       |            |        |           |         |
| D2 DO2 Y2                     |      | DVP data output port 2                                  |         |        |       |            |        |           |         |
| D3 DO3 Y3                     |      | DVP data output port 3                                  |         |        |       |            |        |           |         |
| D4 DO4 Y4                     |      | DVP data output port 4                                  |         |        |       |            |        |           |         |
| D5 DO5 Y5                     |      | DVP data output port 5                                  |         |        |       |            |        |           |         |
| D6 DO6 Y6                     |      | DVP data output port 6                                  |         |        |       |            |        |           |         |
| D7 DO7 Y7                     |      | DVP data output port 7                                  |         |        |       |            |        |           |         |
| D8 DO8 Y8                     |      | DVP data output port 8                                  |         |        |       |            |        |           |         |
| D9 DO9 Y9                     |      | DVP data output port 9                                  |         |        |       |            |        |           |         |
| D10 DO10 Y10                  |      | DVP data output port 10                                 |         |        |       |            |        |           |         |
| D11 DO11 Y11                  |      | DVP data output port 11                                 |         |        |       |            |        |           |         |



your **BEST** camera module partner

## Cameras Applications



[www.KaiLapTech.com](http://www.KaiLapTech.com)



[www.KaiLapTech.com](http://www.KaiLapTech.com)



[www.KaiLapTech.com](http://www.KaiLapTech.com)

[www.KaiLapTech.com](http://www.KaiLapTech.com)



[www.KaiLapTech.com](http://www.KaiLapTech.com)



[www.KaiLapTech.com](http://www.KaiLapTech.com)



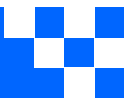

## Camera Reliability Test

| Reliability Inspection Item |  | Testing Method  | Acceptance Criteria     |                         |
|-----------------------------|--|---|-------------------------|-------------------------|
| Category                    | Item   |   |                         |                         |
| Environmental               | Storage Temperature                                      | High 60°C 96 Hours  | Temperature Chamber     | No Abnormal Situation   |
|                             |  | Low -20°C 96 Hours  | Temperature Chamber     | No Abnormal Situation   |
|                             | Operation Temperature                                    | High 60°C 24 Hours  | Temperature Chamber     | No Abnormal Situation   |
|                             |  | Low -20°C 24 Hours  | Temperature Chamber     | No Abnormal Situation   |
|                             | Humidity   | 60°C 80% 24 Hours   | Temperature Chamber     | No Abnormal Situation   |
|                             | Thermal Shock  | High 60°C 0.5 Hours<br>Low -20°C 0.5 Hours<br>Cycling in 24 Hours | Temperature Chamber     | No Abnormal Situation   |
| Physical                    | Drop Test (Free Falling)                                 | Without Package 60cm  | 10 Times on Wood Floor  | Electrically Functional |
|                             |  | With Package 60cm   | 10 Times on Wood Floor  | Electrically Functional |
|                             | Vibration Test   | 50Hz X-Axis 2mm 30min   | Vibration Table         | Electrically Functional |
|                             |  | 50Hz Y-Axis 2mm 30min   | Vibration Table         | Electrically Functional |
|                             |  | 50Hz Z-Axis 2mm 30min   | Vibration Table         | Electrically Functional |
| Cable Tensile Strength Test | Loading Weight 4 kg<br>60 Seconds<br>Cycling in 24 Hours | Tensile Testing Machine   | Electrically Functional |                         |
| Electrical                  | ESD Test   | Contact Discharge 2 KV  | ESD Testing Machine     | Electrically Functional |
|                             |  | Air Discharge 4 KV  | ESD Testing Machine     | Electrically Functional |
|                             | Aging Test   | On/Off 30 Seconds<br>Cycling in 24 Hours                          | Power Switch            | Electrically Functional |
|                             | USB Connector  | On/Off 250 Times  | Plug and Unplug         | Electrically Functional |



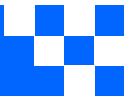

| Inspection Item  |          | Inspection Method | Standard of Inspection      |  |
|------------------|----------|-------------------|-----------------------------|--|
| Category         | Item     |                   |                             |  |
| Appearance       | FPC/ PCB | Color             | The Naked Eye               | Major Difference is Not Allowed.           |
|                  |          | Be Torn/Chopped   | The Naked Eye               | Copper Crack Exposure is Not Allowed.      |
|                  |          | Marking           | The Naked Eye               | Clear, Recognizable (Within 30cm Distance) |
|                  | Holder   | Scratches         | The Naked Eye               | The Inside Crack Exposure is Not Allowed   |
|                  |          | Gap               | The Naked Eye               | Meet the Height Standard                   |
|                  |          | Screw             | The Naked Eye               | Make Sure Screws Are Presented (If Any)    |
|                  |          | Damage            | The Naked Eye               | The Inside Crack Exposure is Not Allowed   |
|                  | Lens     | Scratch           | The Naked Eye               | No Effect On Resolution Standard           |
|                  |          | Contamination     | The Naked Eye               | No Effect On Resolution Standard           |
|                  |          | Oil Film          | The Naked Eye               | No Effect On Resolution Standard           |
|                  |          | Cover Tape        | The Naked Eye               | No Issue On Appearance.                    |
|                  | Function | Image             | No Communication            | Test Board                                 |
| Bright Pixel     |          |                   | Black Board                 | Not Allowed In the Image Center            |
| Dark Pixel       |          |                   | White board                 | Not Allowed In the Image Center            |
| Blurry           |          |                   | The Naked Eye               | Not Allowed                                |
| No Image         |          |                   | The Naked Eye               | Not Allowed                                |
| Vertical Line    |          |                   | The Naked Eye               | Not Allowed                                |
| Horizontal Line  |          |                   | The Naked Eye               | Not Allowed                                |
| Light Leakage    |          |                   | The Naked Eye               | Not Allowed                                |
| Blinking Image   |          |                   | The Naked Eye               | Not Allowed                                |
| Bruise           |          |                   | Inspection Jig              | Not Allowed                                |
| Resolution       |          |                   | Chart                       | Follows Outgoing Inspection Chart Standard |
| Color            |          |                   | The Naked Eye               | No Issue                                   |
| Noise            |          |                   | The Naked Eye               | Not Allowed                                |
| Corner Dark      |          |                   | The Naked Eye               | Less Than 100px By 100px                   |
| Color Resolution |          |                   | The Naked Eye               | No Issue                                   |
| Dimension        | Height   | The Naked Eye     | Follows Approval Data Sheet |  |
|                  | Width    | The Naked Eye     | Follows Approval Data Sheet |  |
|                  | Length   | The Naked Eye     | Follows Approval Data Sheet |  |
|                  | Overall  | The Naked Eye     | Follows Approval Data Sheet |  |

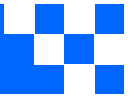

## KLT Package Solutions

KLT Camera Module



Complete with Lens Protection Film

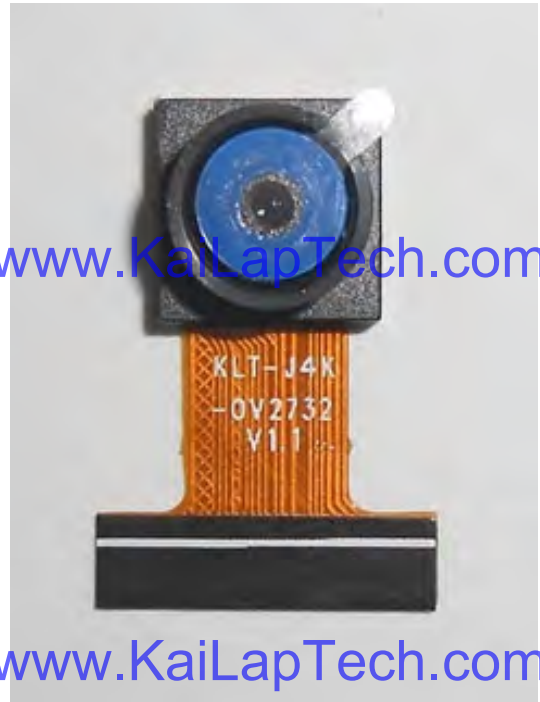

Tray with Grid and Space



Place Cameras on the Tray





## Camera Modules Package Solution

Full Tray of Cameras



Cover Tray with Lid



Put Tray into Anti-Static Bag



Vacuum the Anti-Static Bag

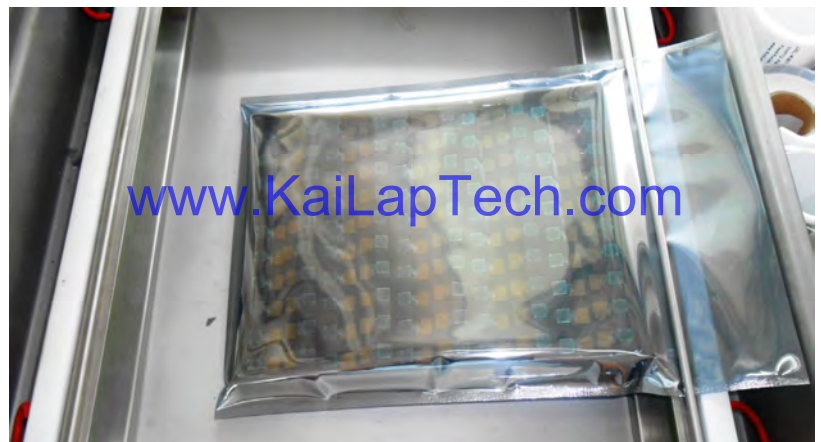





## Camera Modules Package Solution

**Sealed Vacuum Bag with Labels**

- 1. Model and Description 2. Quantity 3. Shipping Date 4. Caution**





# CMOS CAMERA MODULES



*your BEST camera module partner*

## Large Order Package Solution

Place Foam Sheets Between Trays

Foam Sheets are Slightly Larger than Trays

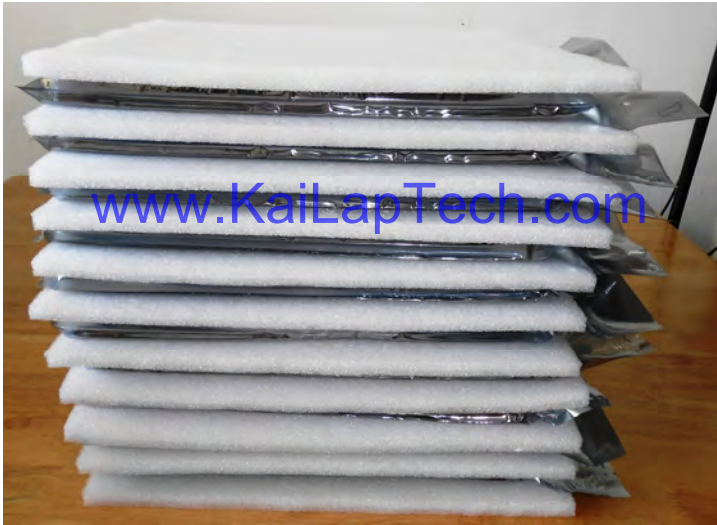

[www.KaiLapTech.com](http://www.KaiLapTech.com)

[www.KaiLapTech.com](http://www.KaiLapTech.com)

Place Foam Sheets and Trays into Box

Foam Sheets are Tightly Fitting Box



[www.KaiLapTech.com](http://www.KaiLapTech.com) [sales@KaiLapTech.com](mailto:sales@KaiLapTech.com) Tel: (852) 6908 1256 Fax: (852) 3017 6778

All rights reserved @ Kai Lap Technologies Group Ltd. Specifications subject to change without notice.



# CMOS CAMERA MODULES



*your BEST camera module partner*

## Small Order Package Solution

Place Foam Sheets and Trays into Small Box



[www.KaiLapTech.com](http://www.KaiLapTech.com)

Package in Small Box for Shipment

Foam Sheets are Nicely Fitting the Small Box



[www.KaiLapTech.com](http://www.KaiLapTech.com)

Place Small Boxes into Larger Box



[www.KaiLapTech.com](http://www.KaiLapTech.com) [sales@KaiLapTech.com](mailto:sales@KaiLapTech.com) Tel: (852) 6908 1256 Fax: (852) 3017 6778

All rights reserved @ Kai Lap Technologies Group Ltd. Specifications subject to change without notice.

## Carbon Box Package Solution

Seal the Carbon Box

Final Package Labelled Box



### Carbon Box Ready for Shipment

1. Delivery Address and Phone No.
2. Box No. and Ship Date
3. Fragile Caution





## Sample Order Package Solution

Place Sample into Small Anti-Static Bag



Place Connectors into Small Ant-Static Bag



### Sample Labels on the Small Bag

1. Camera Module or Connector Model
2. Shipping Date and Quantity
3. Caution



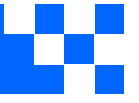

## Connectors Large Order Package Solution

Connectors in a Wheel



Label Connectors in the Wheel



The Wheel is Perfectly Fitting the Box



Connectors Box Ready for Shipment



## Company Kai Lap Technologies (KLT)

Kai Lap Technologies Group Limited. (KLT) was established in 2009, a next-generation technology driven manufacturer specialized in research, design, and produce of audio and video products. KLT is occupying 20,000 square feet automated plants with 100 employees of annual throughput 30,000,000 units cameras.

KLT provides OEM, ODM design, contract manufacturing, and builds the camera products. You may provide the requirements to us, even with a hand draft, our sales and engineering work together to meet your needs. We consider ourselves your last-term partner in developing practical and innovative solutions.

Our team covers everything from initial concept development to mass produced product. KLT specializes in customized camera design, raw material, electronic engineering, firmware/software development, product testing, and packing design. Our experienced strategic supply systems offer a robust and dependable manufacturing capacity for orders of various sizes.

[www.KaiLapTech.com](http://www.KaiLapTech.com)

[www.KaiLapTech.com](http://www.KaiLapTech.com)



## Limited Warranty

KLT provides the following limited warranty if you purchased the Product(s) directly from KLT company or from KLT's website, [www.KaiLapTech.com](http://www.KaiLapTech.com). Product(s) purchased from other sellers or sources are not covered by this Limited Warranty. KLT guarantees that the Product(s) will be free from defects in materials and workmanship under normal use for a period of one (1) year from the date you receive the product ("Warranty Period").

For all Product(s) that contain or develop material defects in materials or workmanship during the Warranty Period, KLT will, at its sole option, either: (i) repair the Product(s); (ii) replace the Product(s) with a new or refurbished Product(s) (replacement Product(s) being of identical model or functional equivalent); or (iii) provide you a refund of the price you paid for the Product(s).

This Limited Warranty of KLT is solely limited to repair and/or replacement on the terms set forth above. KLT is not reliable or responsible for any subsequent events.





# CMOS CAMERA MODULES

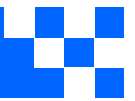

*your BEST camera module partner*

## KLT Strength

### Powerful Factory



### Professional Service



### Promised Delivery



[www.KaiLapTech.com](http://www.KaiLapTech.com)   [sales@KaiLapTech.com](mailto:sales@KaiLapTech.com)   Tel: (852) 6908 1256   Fax: (852) 3017 6778

All rights reserved @ Kai Lap Technologies Group Ltd. Specifications subject to change without notice.